

6

5

4

3

2

1

REVISION RECORD			
LTR	ECO NO:	APPROVED:	DATE:

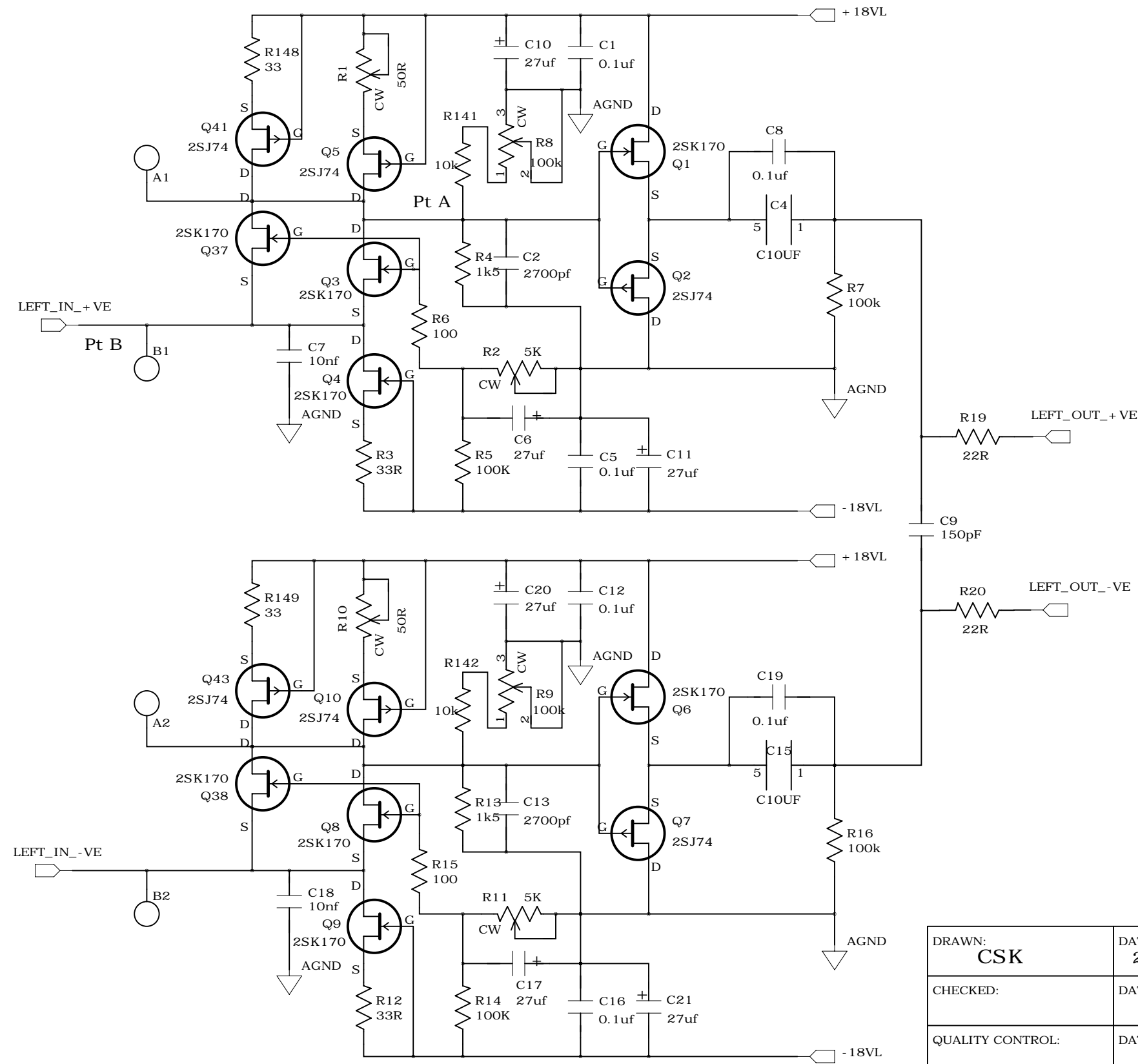

Notes:

- Q1, Q2, Q6, & Q7 use Idss 7-9 mA, matched
- Q3 & Q8 use Idss > 10mA, matched; Q37 & Q38 optional
- Q5 & Q10 use Idss > 14mA, Q41 & Q43 ~ 7mA optional
- Q4 & Q9 use Idss below 6~ 8 mA, Matched
- R8 & R9 to trim output to same ac level, optional
- R1 & R10 to adjust Pt A to half of + ve supply voltage
- R2 & R11 to adjust Pt B to 0Vdc
- R4 & R13 1.5k use best sound resistor; C2 & C13 use silver mica
- All capacitors min 35V dc

D

D

C

C

B

B

A

A

COMPANY: DIY FUN			
TITLE: Jfet IV Left Channel			
DRAWN: CSK	DATED: 20/3/2007		
CHECKED:	DATED:	CODE:	REV: 1
QUALITY CONTROL:	DATED:	SIZE: B	DRAWING NO:
RELEASED:	DATED:	SCALE: Total 8 pages	SHEET: OF 1

6

5

4

3

2

1

REVISION RECORD			
LTR	ECO NO:	APPROVED:	DATE:

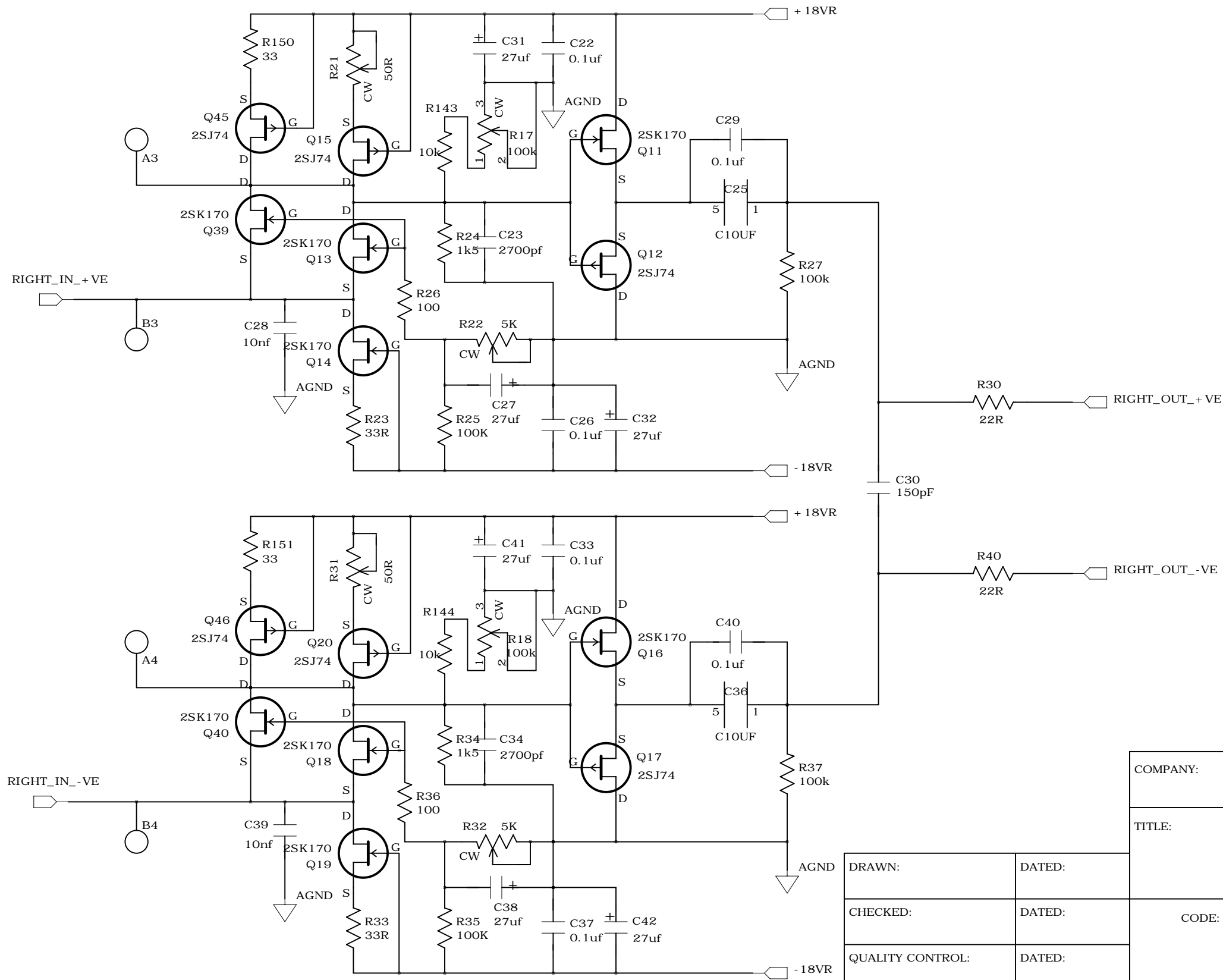

Same notes as in Left Channel Jfet IV

COMPANY:			
TITLE: Jfet IV Right Channel			
CODE:	SIZE: B	DRAWING NO:	REV: A
SCALE:		SHEET: OF 2	

DRAWN:	DATED:
CHECKED:	DATED:
QUALITY CONTROL:	DATED:
RELEASED:	DATED:

D

D

C

C

B

B

A

A

6

5

4

3

2

1

REVISION RECORD			
LTR	ECO NO:	APPROVED:	DATE:

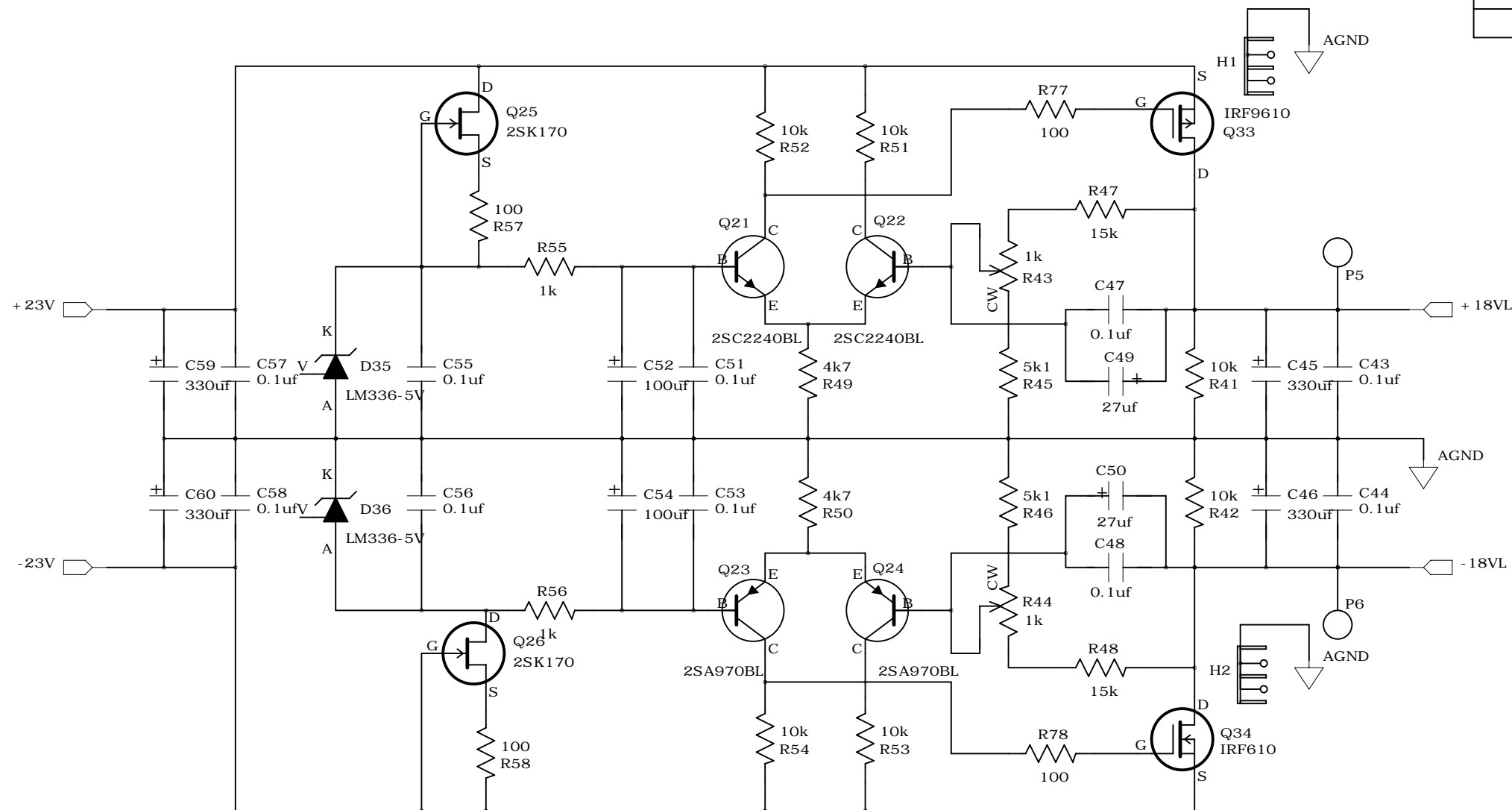

Notes:

Q25 & Q26 use Idss 6-8 mA

R43 & R44 to adjust regulator output voltage

R47 & R48: Higher value give higher regulated voltage and vice verse

All capacitors min 35V dc

COMPANY:

TITLE:

REGULATOR LEFT JFET IV

DRAWN:	DATED:
CHECKED:	DATED:
QUALITY CONTROL:	DATED:
RELEASED:	DATED:

CODE:	SIZE:	DRAWING NO:	REV:
SCALE:			SHEET: OF 3

6

5

4

3

2

1

REVISION RECORD			
LTR	ECO NO:	APPROVED:	DATE:

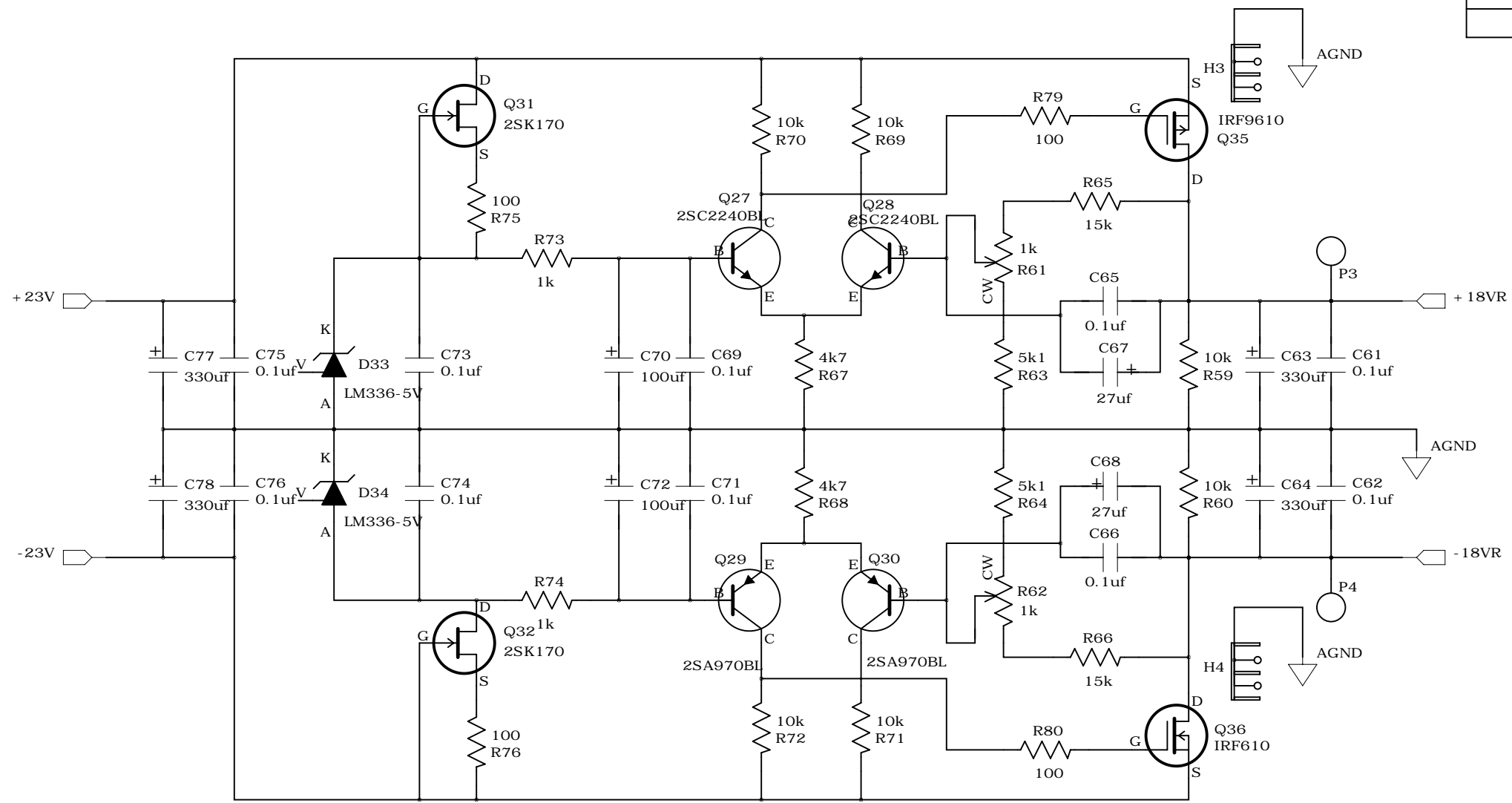

Same notes as in Left Channel Regulator

COMPANY:

TITLE:
REGULATOR RIGHT JFET IV

DRAWN:	DATED:
CHECKED:	DATED:
QUALITY CONTROL:	DATED:
RELEASED:	DATED:

CODE:	SIZE:	DRAWING NO:	REV:
SCALE:			SHEET: OF 4

6

5

4

3

2

1

D

C

B

A

D

C

B

A

REVISION RECORD			
LTR	ECO NO:	APPROVED:	DATE:

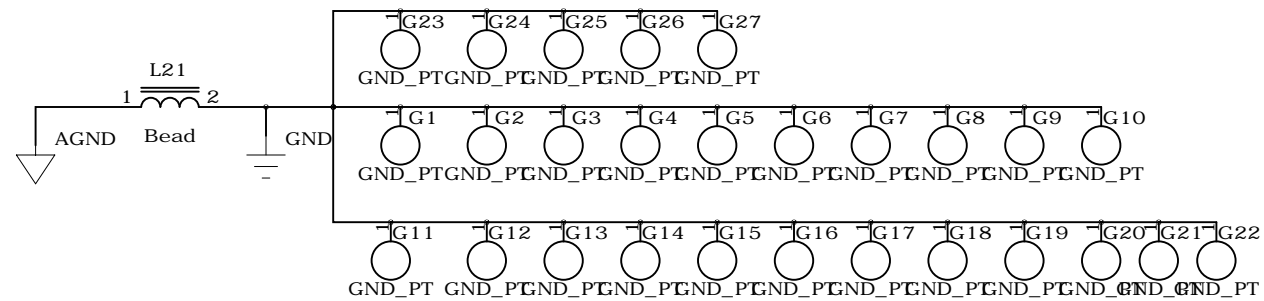
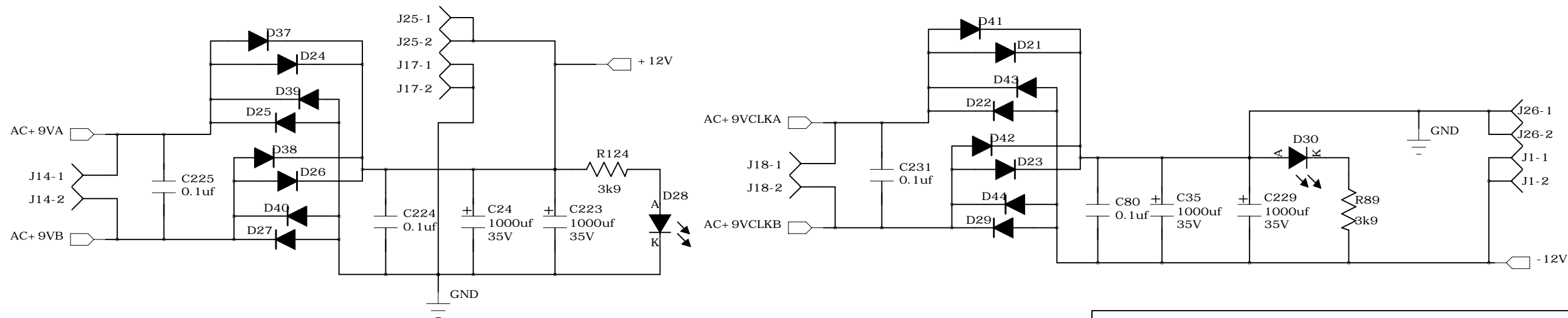
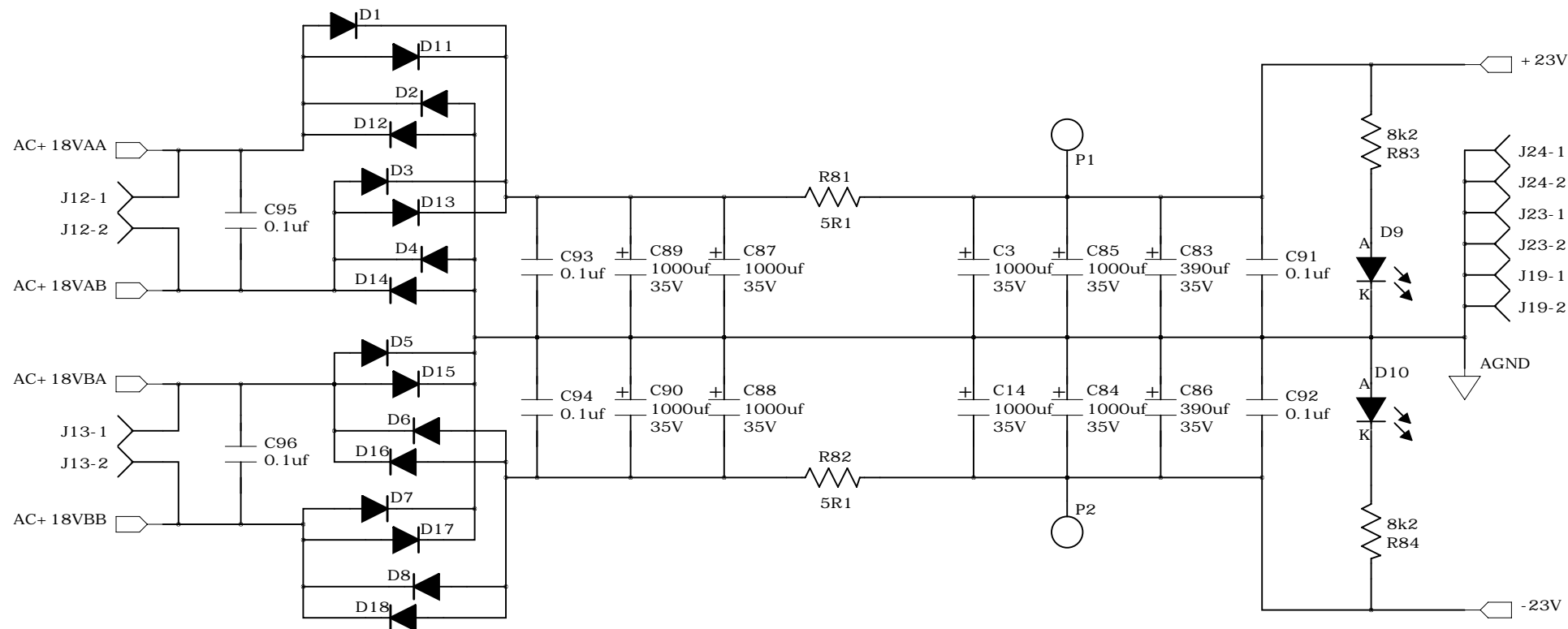

COMPANY:			
TITLE: POWER SUPPLY			
CODE:	SIZE:	DRAWING NO:	REV:
SCALE:		SHEET: OF 8	

DRAWN:	DATED:
CHECKED:	DATED:
QUALITY CONTROL:	DATED:
RELEASED:	DATED:

6 5 4 3 2 1

REVISION RECORD			
LTR	ECO NO:	APPROVED:	DATE:

D

D

C

C

B

B

A

A

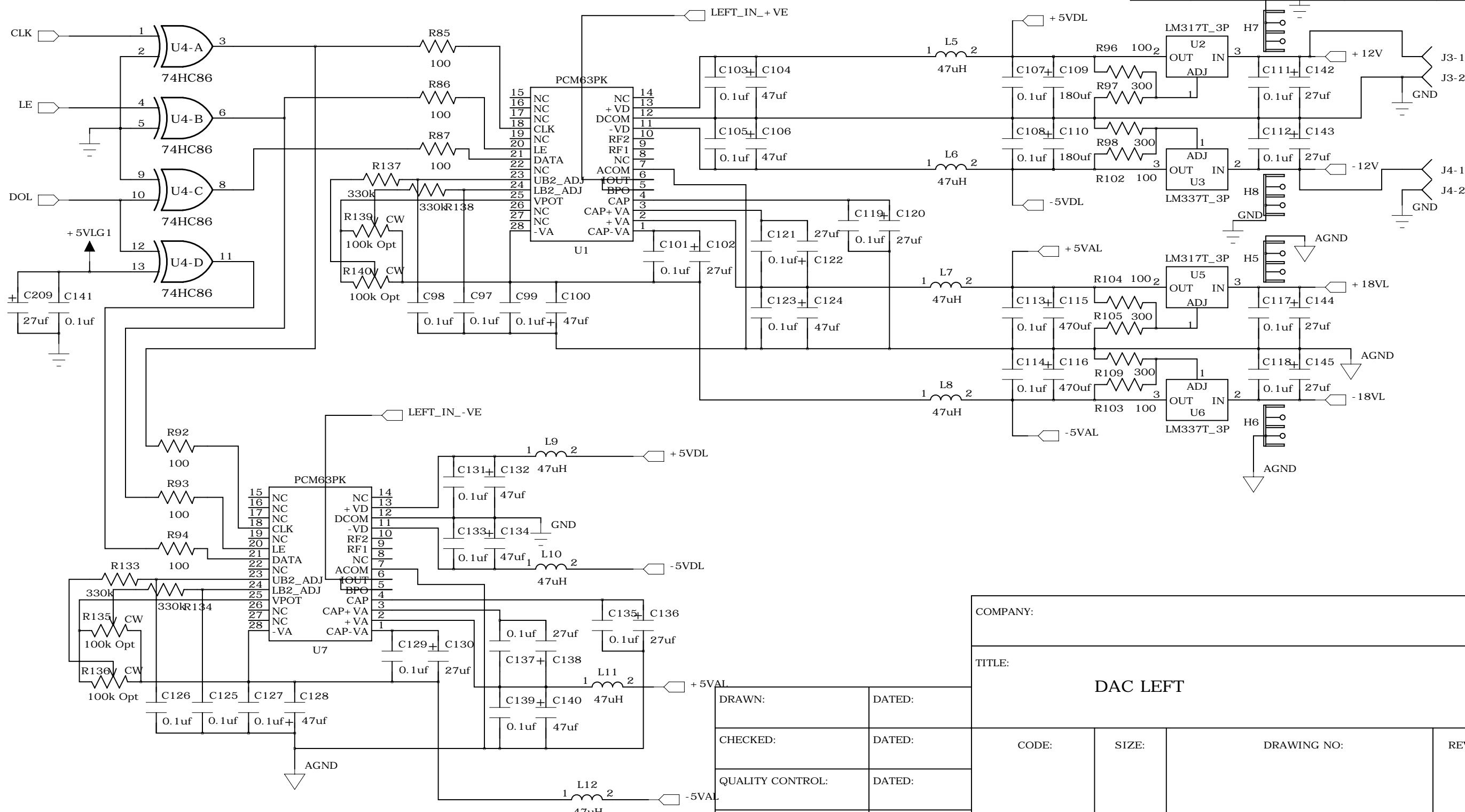

COMPANY:			
TITLE: DAC LEFT			
DRAWN:	DATED:	CODE:	SIZE:
CHECKED:	DATED:	DRAWING NO:	
QUALITY CONTROL:	DATED:	REV:	
RELEASED:	DATED:	SCALE:	SHEET: OF 5

6 5 4 3 2 1

REVISION RECORD			
LTR	ECO NO:	APPROVED:	DATE:

D

D

C

C

B

B

A

A

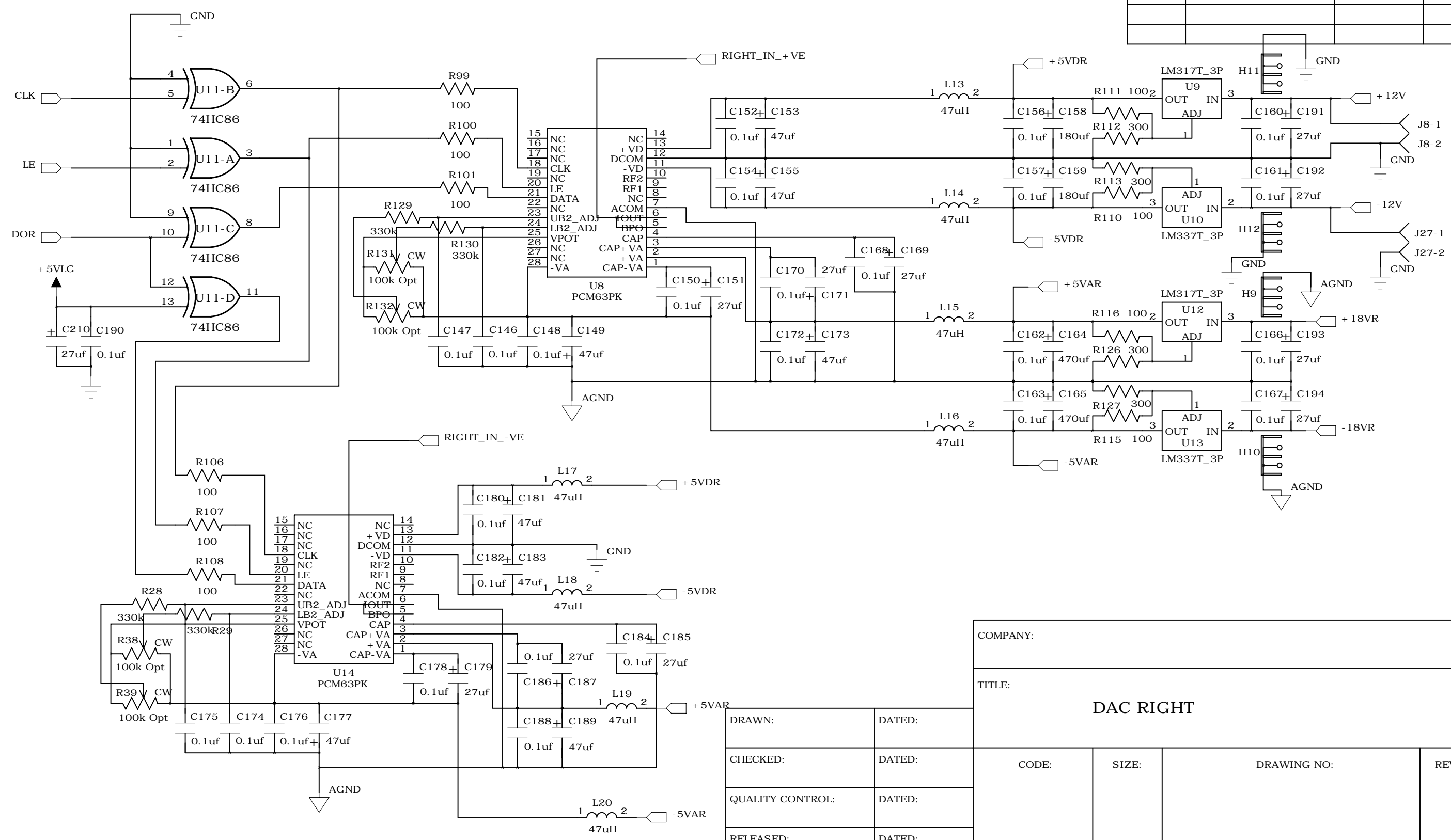

COMPANY:			
TITLE: DAC RIGHT			
DRAWN:	DATED:	CODE:	SIZE:
CHECKED:	DATED:	DRAWING NO:	
QUALITY CONTROL:	DATED:	REV:	
RELEASED:	DATED:	SCALE:	SHEET: OF 6

6

5

4

3

2

1

REVISION RECORD			
LTR	ECO NO:	APPROVED:	DATE:

Notes:

J28 and J29 select 8412/14 o/p bit

18 Bit: J28 short & J29 open

16 Bit: J28 open & J29 short

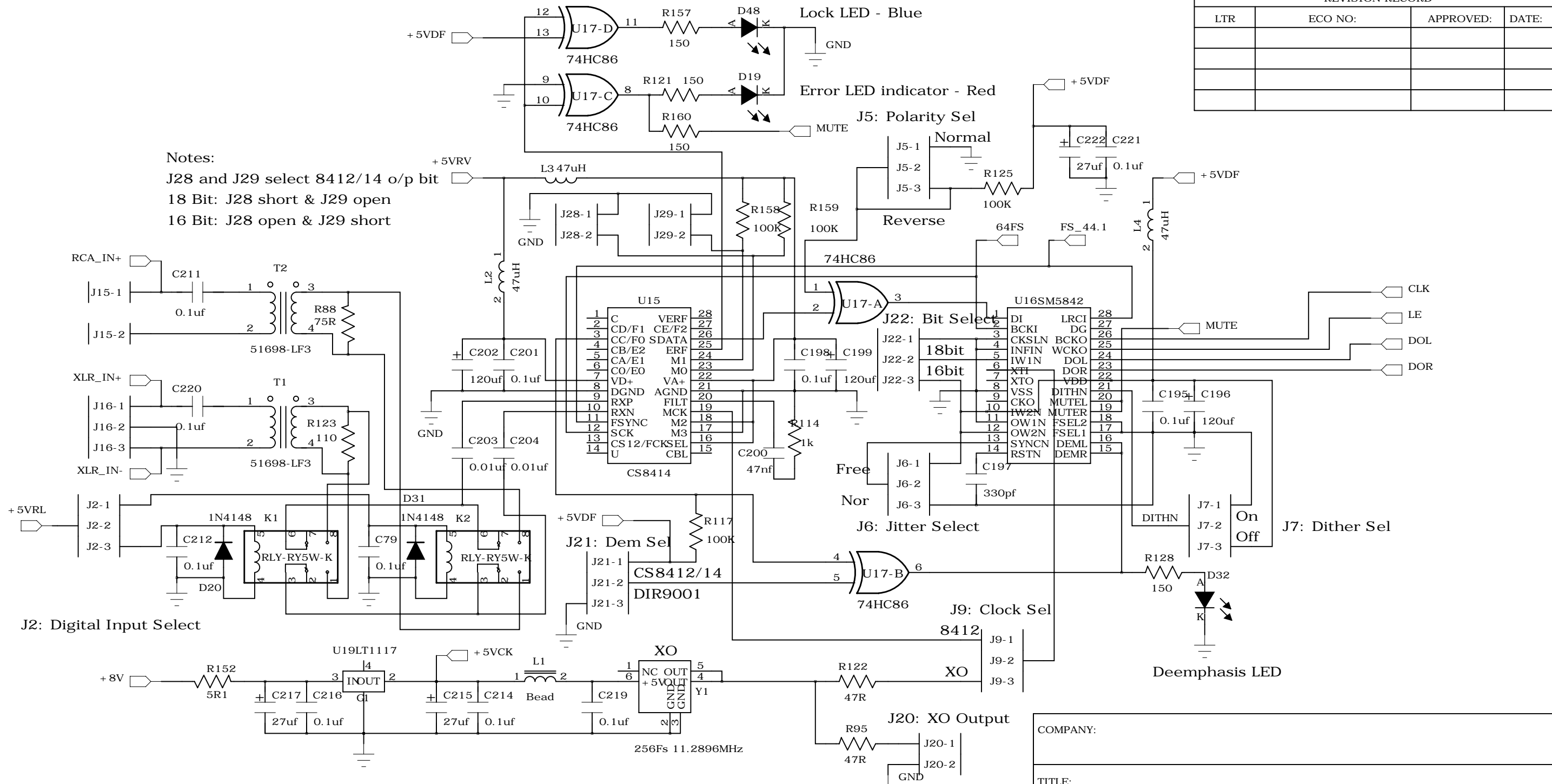

COMPANY:			
TITLE: RECEIVER & DIGITAL FILTER + CLOCK			
DRAWN:	DATED:	CODE:	REV:
CHECKED:	DATED:	SIZE:	DRAWING NO:
QUALITY CONTROL:	DATED:	DRAWING NO:	
RELEASED:	DATED:	SCALE:	SHEET: OF 7

6

5

4

3

2

1

REVISION RECORD			
LTR	ECO NO:	APPROVED:	DATE:

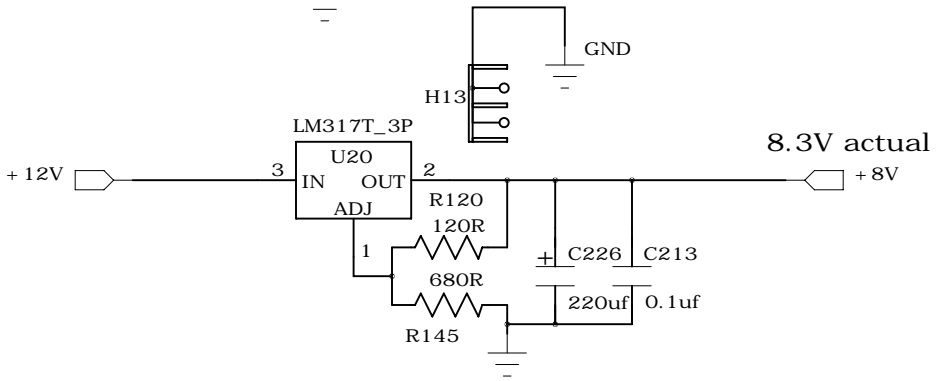
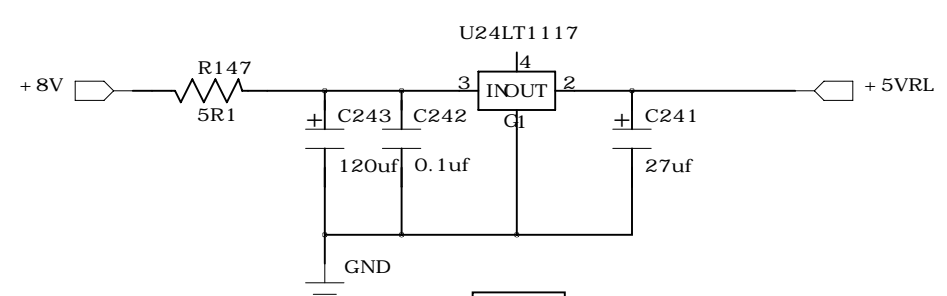
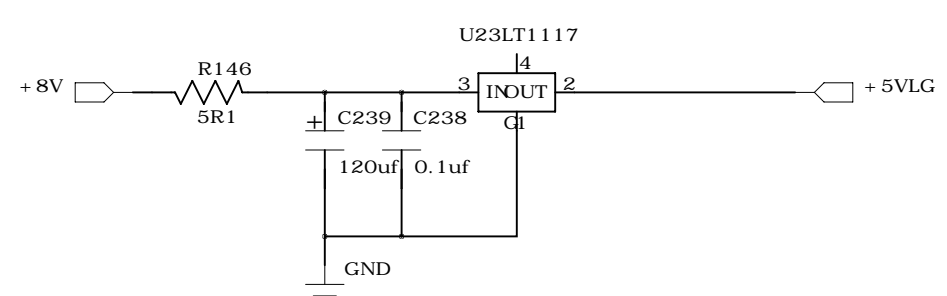
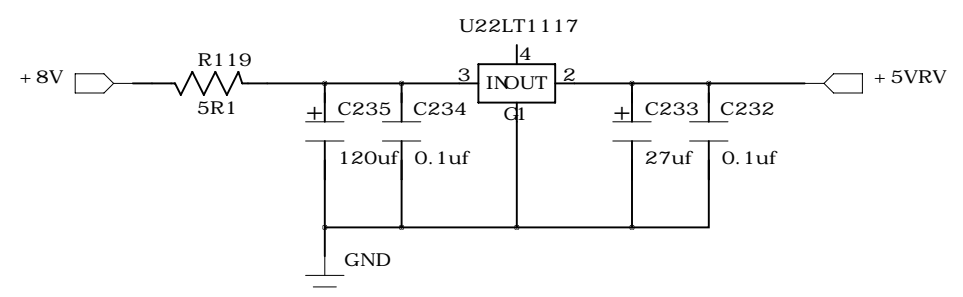
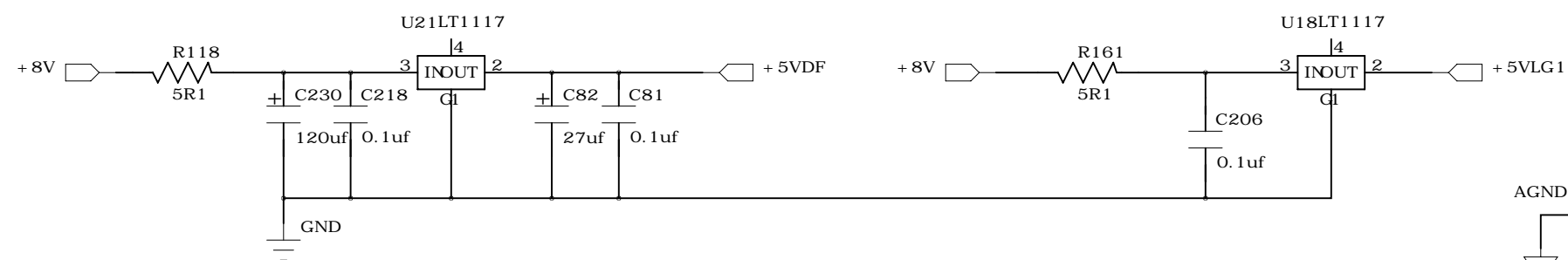

Analogy Ground and Digital Ground Via holes

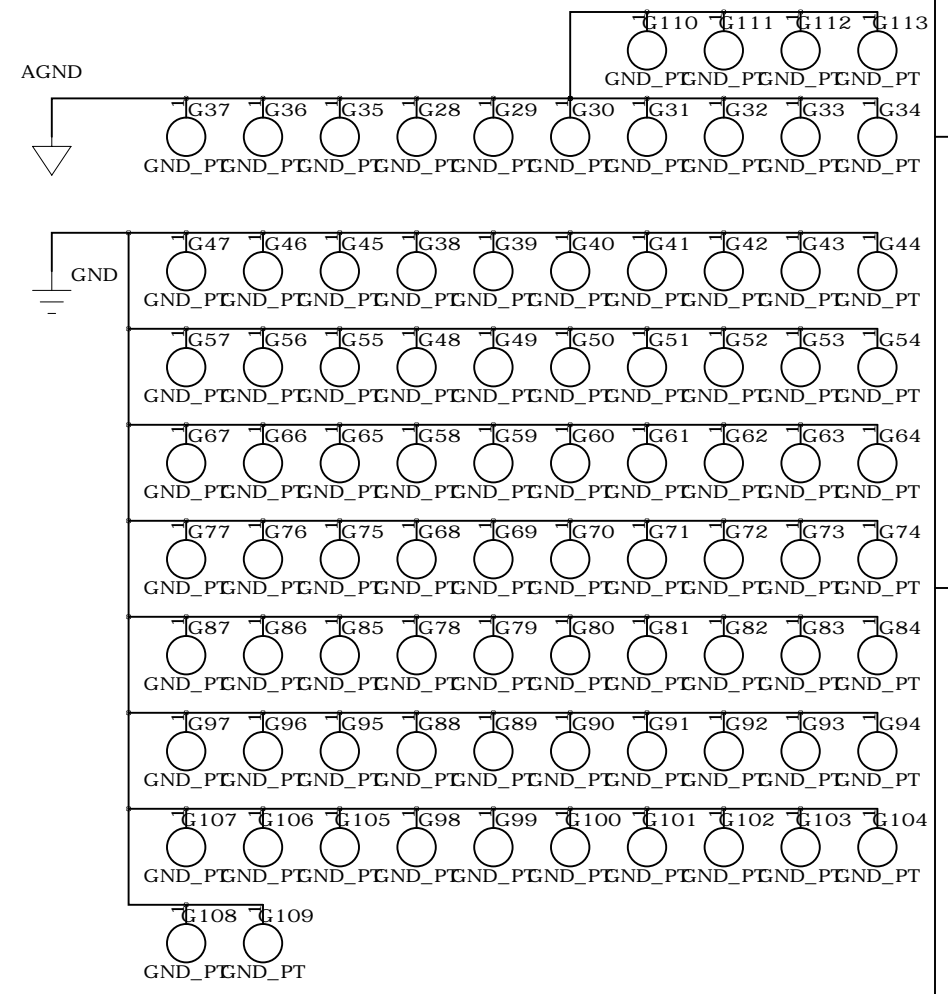

COMPANY:

TITLE:
Digital Supply and pre-regulator

DRAWN:	DATED:
CHECKED:	DATED:
QUALITY CONTROL:	DATED:
RELEASED:	DATED:

CODE:	SIZE:	DRAWING NO:	REV:
SCALE:			SHEET: OF 9

6

5

4

3

2

1

REVISION RECORD			
LTR	ECO NO:	APPROVED:	DATE:

Note: Use either K983/J148 OR IRF610/IRF9610

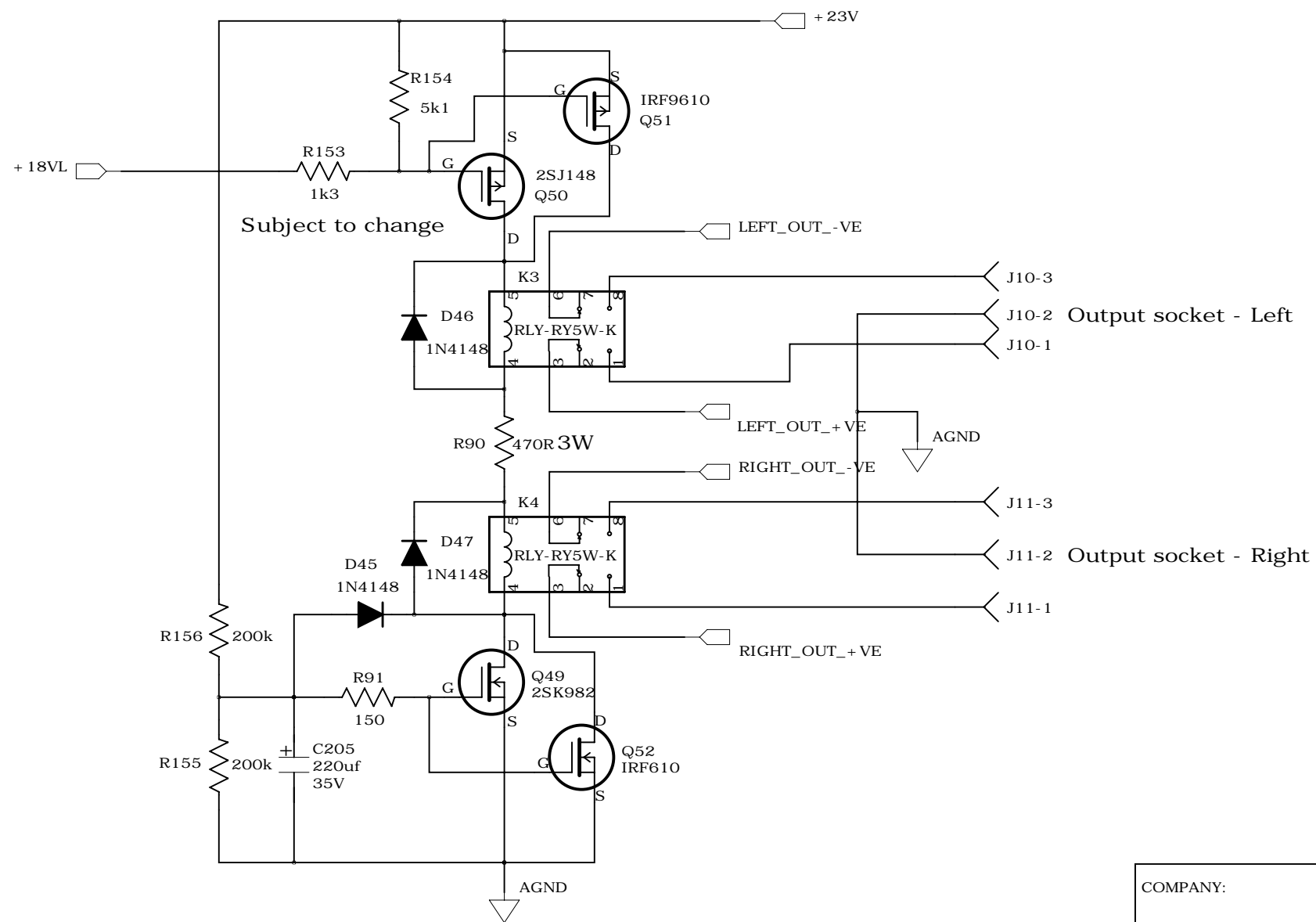

Subject to change

COMPANY:			
TITLE: Output Delay and Mute			
DRAWN:	DATED:	CODE:	SIZE:
CHECKED:	DATED:	DRAWING NO:	
QUALITY CONTROL:	DATED:	REV:	
RELEASED:	DATED:	SCALE:	
SHEET: OF 10			

D

C

B

A

D

C

B

A